

Name: _____

Solutions

This homework is due Monday, June 19th during recitation. If you have questions regarding any of this, feel free to ask during office hours or send me an email. When writing solutions, present your answers clearly and neatly, showing only necessary work.

This assignment will all be about calculating volumes of solids using cross sections. It will be graded for **completion only**. Read through the first page *carefully* and work through the examples *slowly*.

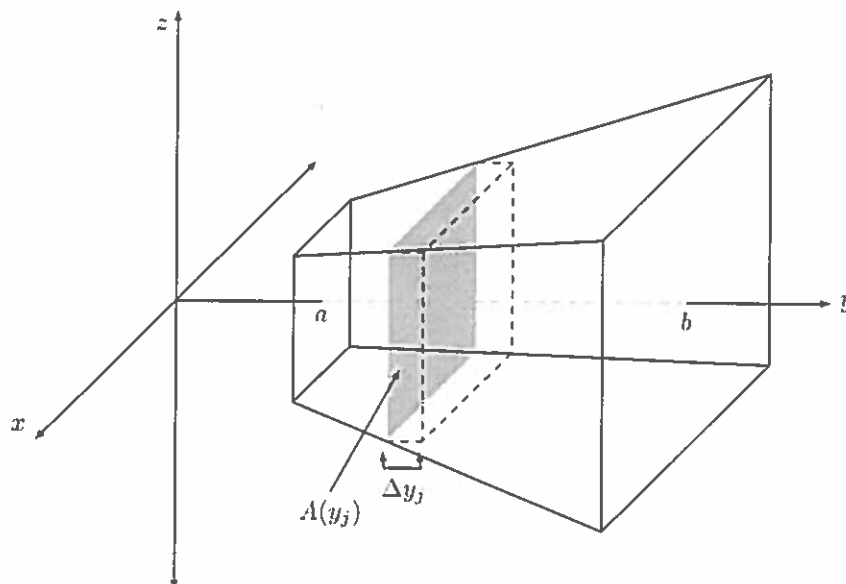

The solid above is not one that can be formed by revolving a curve about an axis, so we cannot use our formulas for those solids to calculate its volume. But we can take a similar approach.

Recall that we calculate volumes of solids of revolution by calculating volumes of discs inside the solid, summing them up and taking a limit. Now, instead of discs, we have boxes.

Imagine filling the solid above with boxes just like the one shown. Then we can approximate the volume of that solid by summing the volumes of the boxes. The area of the box will be the area of one of its faces, $A(y_j)$, multiplied by the width of the box, Δy_j . Thus we obtain:

$$V \approx \sum_{j=1}^n A(y_j) \Delta y_j,$$

where n is the number of boxes.

It should be fairly clear to see that using more boxes will result in a better approximation, just as using more rectangles gave a better approximation of area under a curve. To get the exact volume we must take a limit as the number of boxes approaches infinity, i.e. $n \rightarrow \infty$, just as we did with Riemann sums. Thus we obtain:

$$V = \lim_{n \rightarrow \infty} \sum_{j=1}^n A(y_j) \Delta y_j = \int_a^b A(y) dy.$$

This is what we shall call the *cross-section volume formula*. There was nothing special about the y -axis here, you can cut across any axis and integrate over that one instead. In fact you can slice through the solid in any direction you like and still obtain a volume formula similar to the one above. For the sake of keeping things simple however, we will stick with just this one. Now work through the following two examples to help make sense of the processes involved.

Consider the tetrahedron with vertices $(0, 0, 0)$, $(1, 0, 0)$, $(0, 2, 0)$ and $(0, 0, 3)$. Let us fix a point along the y -axis and take a cross section to obtain a triangle (pictured below).

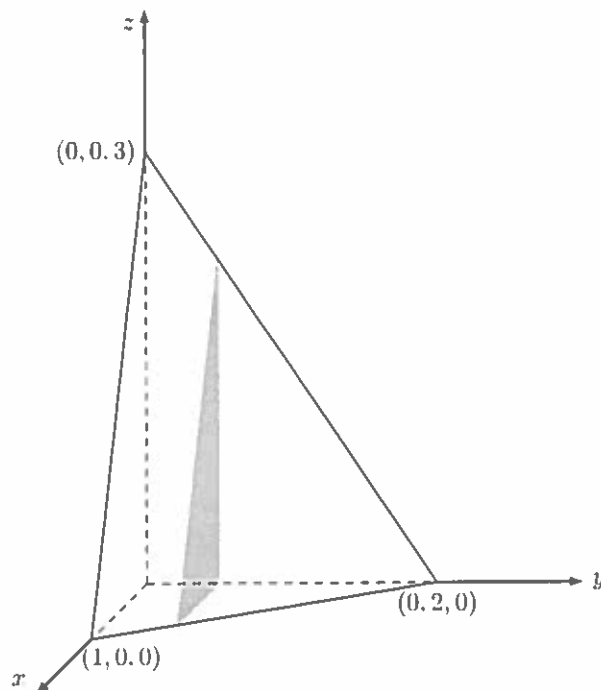

The area of this triangle can be determined based on the value of y we cut at. It has base length equal to its x -coordinate and height equal to its z -coordinate. From its area we will use the cross-section volume formula to determine the volume of the tetrahedron.

- a) In terms of y , determine the height of this triangle. That is, express z as a function of y .
To do this it may be helpful to view the tetrahedron from the side.

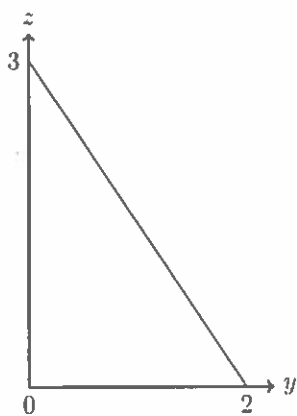

$$z = my + c$$

$$m = \frac{z_2 - z_1}{y_2 - y_1} = \frac{3 - 0}{0 - 2} = -\frac{3}{2}$$

$$z = -\frac{3}{2}y + c$$

$$3 = 0 + c \Rightarrow c = 3$$

$$z = -\frac{3}{2}y + 3$$

Answer: $z = 3 - \frac{3}{2}y$

- b) In terms of y , determine the base length of this triangle. That is, express x as a function of y . To do this it may be helpful to view the tetrahedron from underneath.

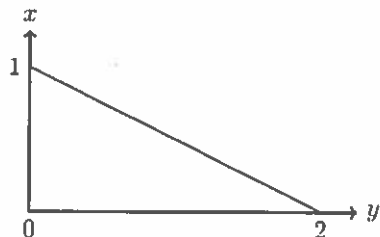

$$x = my + c$$

$$m = \frac{x_2 - x_1}{y_2 - y_1} = \frac{1 - 0}{0 - 2} = -\frac{1}{2}$$

$$x = -\frac{1}{2}y + c$$

$$1 = 0 + c \Rightarrow c = 1$$

$$x = -\frac{1}{2}y + 1$$

Answer: $x = 1 - \frac{1}{2}y$

- c) In terms of y , determine the area of this triangle. That is, find a function $A(y)$ that represents the area of the triangular cross section at the point y . Simplify your answer the best you can. Recall the area of a triangle is $\frac{1}{2} \times \text{base length} \times \text{height}$.

$$A(y) = \frac{1}{2} x(y) z(y) = \frac{1}{2} (1 - \frac{1}{2}y)(3 - \frac{3}{2}y)$$

$$= \frac{3}{2} (1 - \frac{1}{2}y)^2$$

Answer: $A(y) = \frac{3}{2} (1 - \frac{1}{2}y)^2$

- d) Using your area function above, calculate the volume of the tetrahedron.

$$V = \int_a^b A(y) dy = \int_0^2 \frac{3}{2} (1 - \frac{1}{2}y)^2 dy$$

$$= - (1 - \frac{1}{2}y)^3 \Big|_0^2$$

$$= - (1 - 1)^3 + (1 - 0)^3$$

$$= 0 + 1$$

$$= 1$$

Answer: 1

Consider a rectangular based pyramid of side lengths 4cm and 6cm and of height 5cm . Let us fix a point along the y -axis and take a cross section to obtain a rectangle (pictured below).

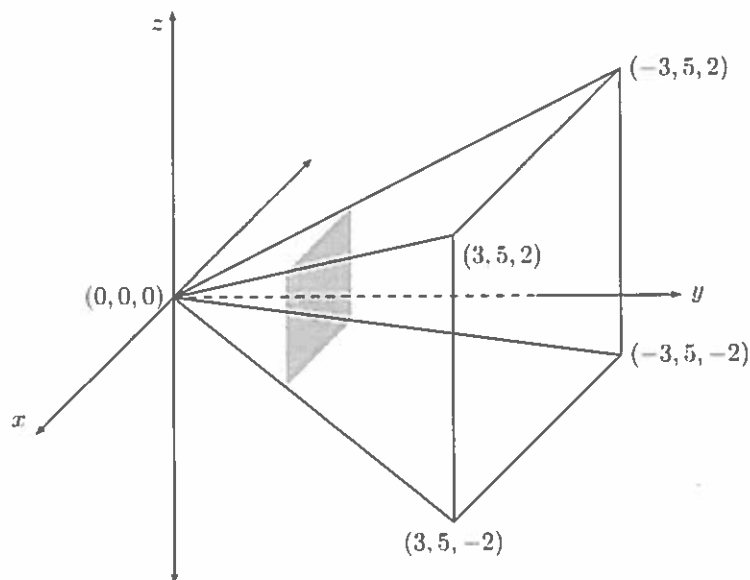

The area of this rectangle can be determined based on the value of y we cut at. It has side lengths equal to its x -coordinate and z -coordinate. From its area we will use the cross-section volume formula to determine the volume of the pyramid.

For this problem it is useful to look at the pyramid from its point.

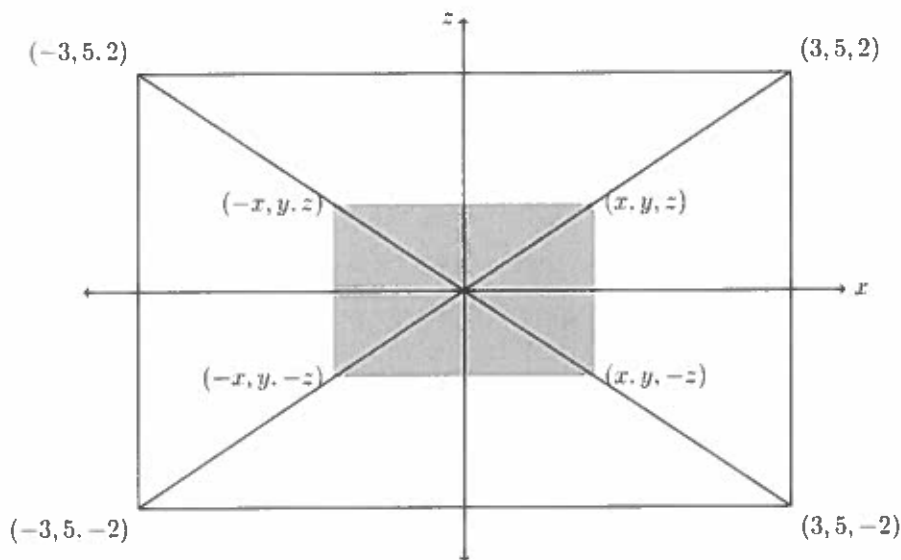

We can see that the area of the shaded region is split between the four quadrants (x, z) , $(-x, z)$, $(-x, -z)$ and $(x, -z)$. So we can calculate the area of the shaded region in just one quadrant, say the (x, z) one, and just multiply that by 4. This will make our calculations simpler.

The picture below shows that the area of one quadrant will give rise to to one quarter of the volume of the whole solid.

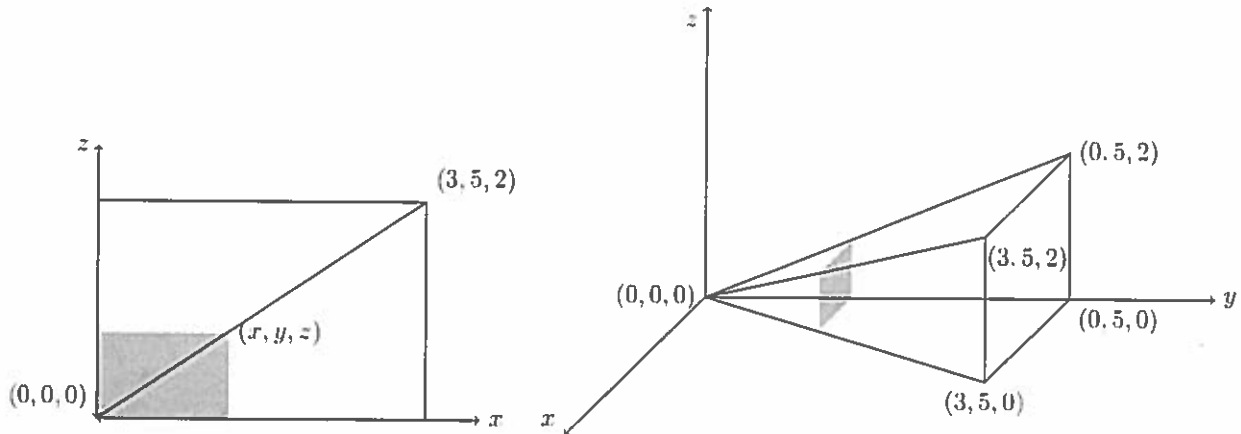

- a) In terms of y , determine length of the side corresponding to the x -coordinate. That is, express x as a function of y . To do this it may be helpful to view the quarter-pyramid from below.

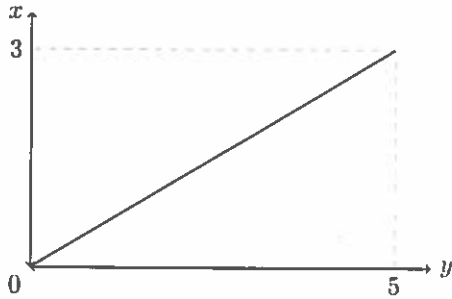

$$x = my + c$$

$$m = \frac{x_2 - x_1}{y_2 - y_1} = \frac{3 - 0}{5 - 0} = \frac{3}{5}$$

$$x = \frac{3}{5}y + c$$

$$0 = 0 + c \implies c = 0$$

$$x = \frac{3}{5}y$$

Answer: $x = \frac{3}{5}y$

- b) In terms of y , determine length of the side corresponding to the z -coordinate. That is, express z as a function of y . To do this it may be helpful to view the quarter-pyramid from its side.

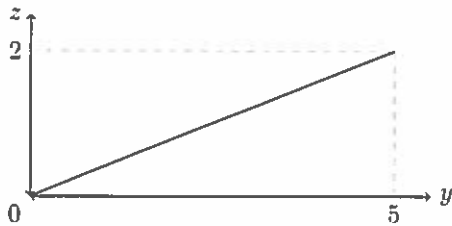

$$z = my + c$$

$$m = \frac{z_2 - z_1}{y_2 - y_1} = \frac{2 - 0}{5 - 0} = \frac{2}{5}$$

$$z = \frac{2}{5}y + c$$

$$0 = 0 + c \implies c = 0$$

$$z = \frac{2}{5}y$$

Answer: $z = \frac{2}{5}y$

c) In terms of y , determine the area $A(y)$ of the quarter-pyramid cross section. Simplify your answer the best you can.

$$A(y) = x(y)z(y) = \left(\frac{3}{5}y\right)\left(\frac{2}{5}y\right) = \frac{6}{25}y^2$$

Answer: $A(y) = \frac{6}{25}y^2$

d) Multiply your answer for $A(y)$ above by 4 to find the area of the cross section of the full pyramid in terms of y .

Answer: $A(y) = \frac{24}{25}y^2$

e) Using your area function above, calculate the volume of the pyramid.

$$\begin{aligned} V &= \int_0^5 A(y) dy = \int_0^5 \frac{24}{25} y^2 dy \\ &= \frac{8}{25} y^3 \Big|_0^5 \\ &= \frac{8}{25} [125 - 0] \\ &= 40 \end{aligned}$$

Answer: 40